

LOC		DIST		P		F		ZONE		LTR		REVISIONS			
BD	48											DESCRIPTION	DATE	APPD	
												0	RELEASED PER NPR 2503	1-22-90	-
												A	REV PER EC 0020-117-93	03/17/93	SB
												B	REV PER EC 0020-309-95	05/04/95	JS
												C	REV PER EC 0020-881-95	25 AUG 95	JS

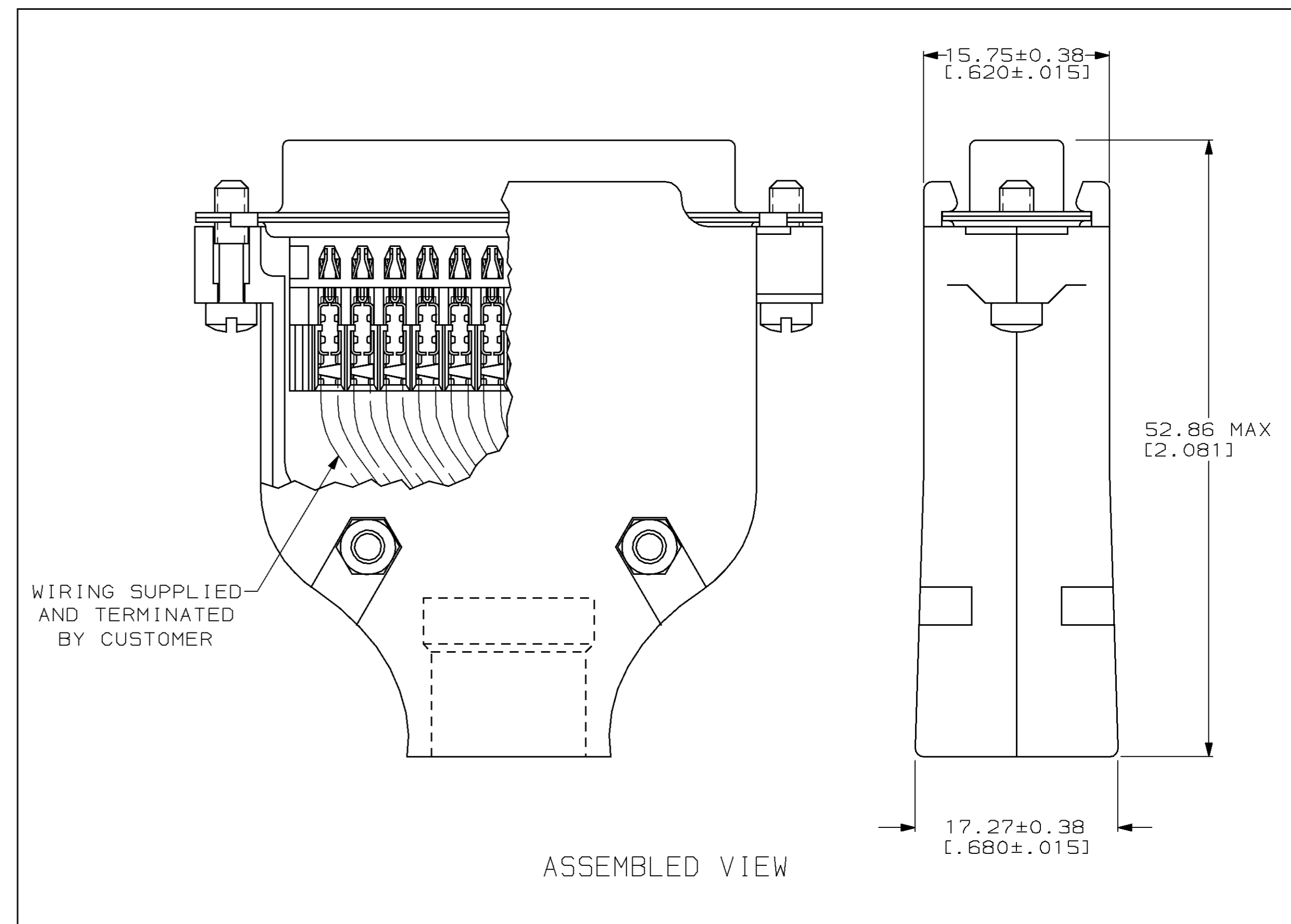
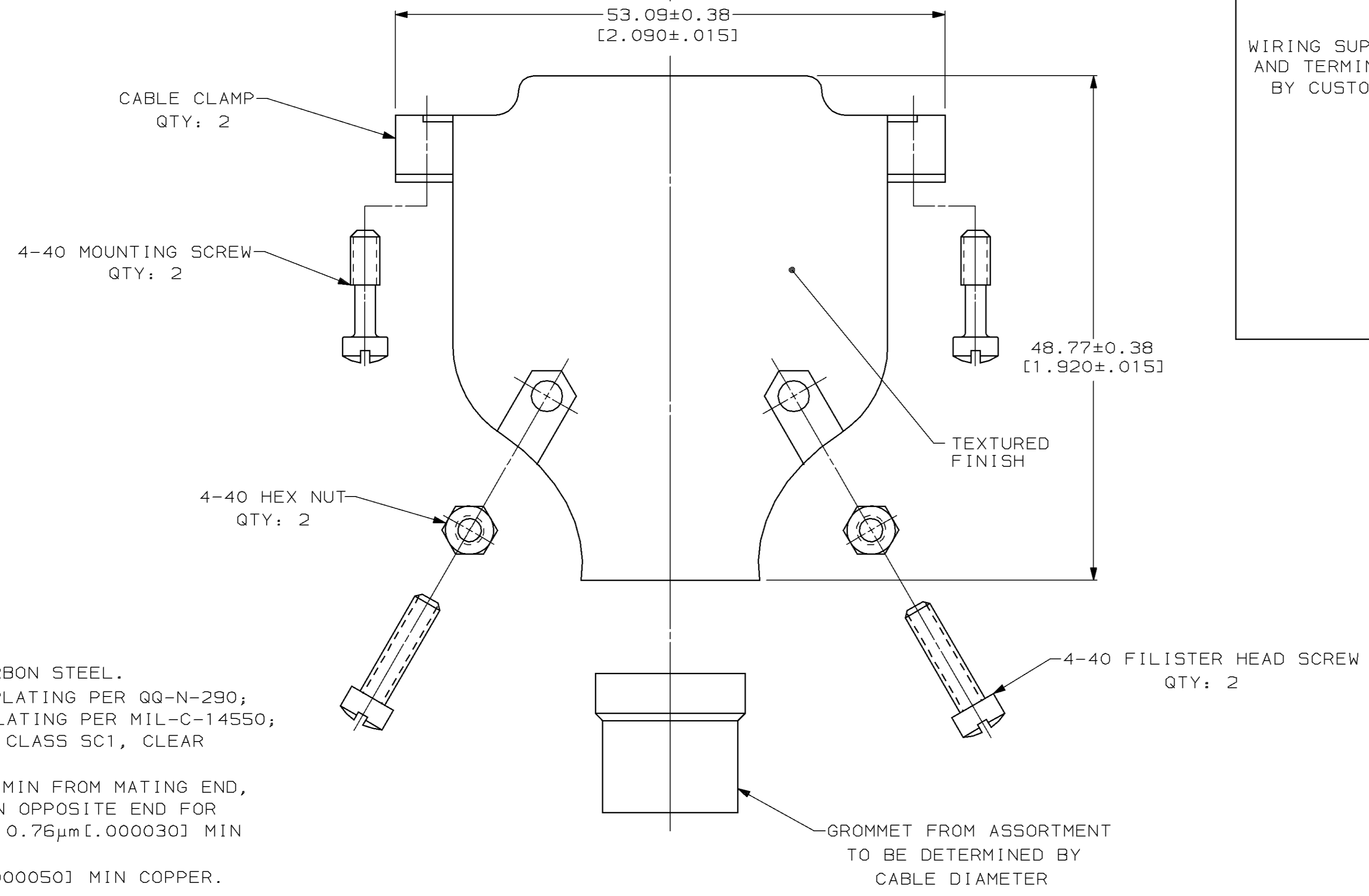
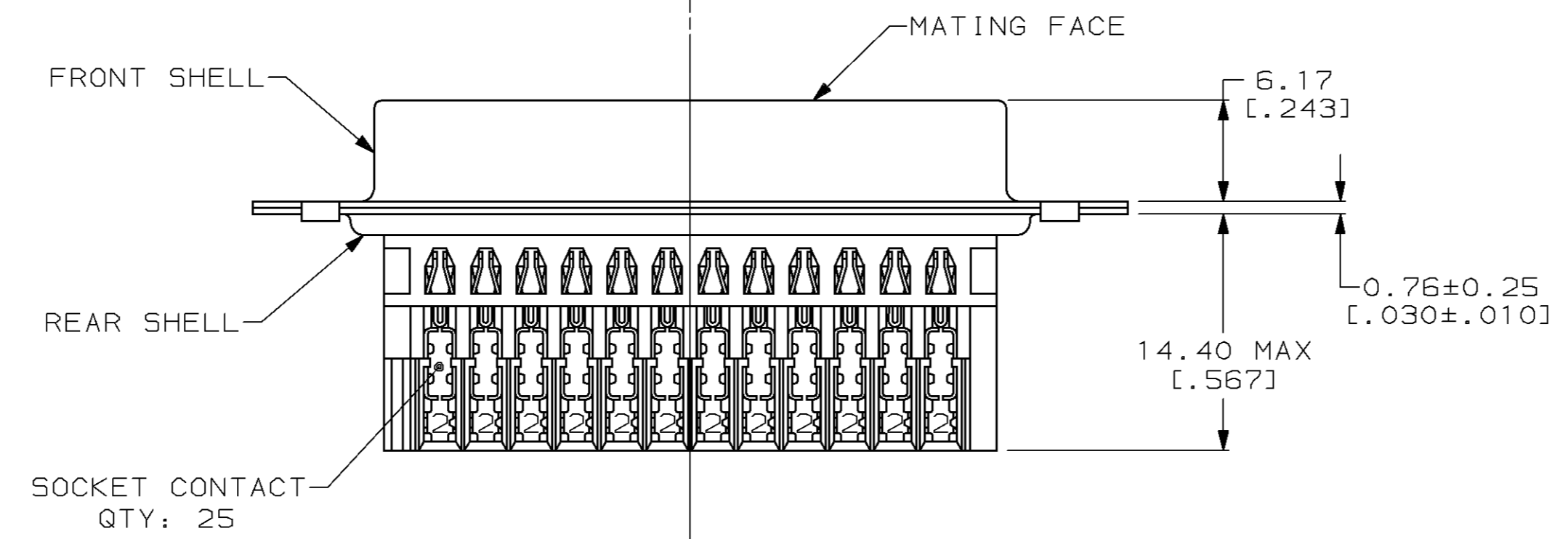
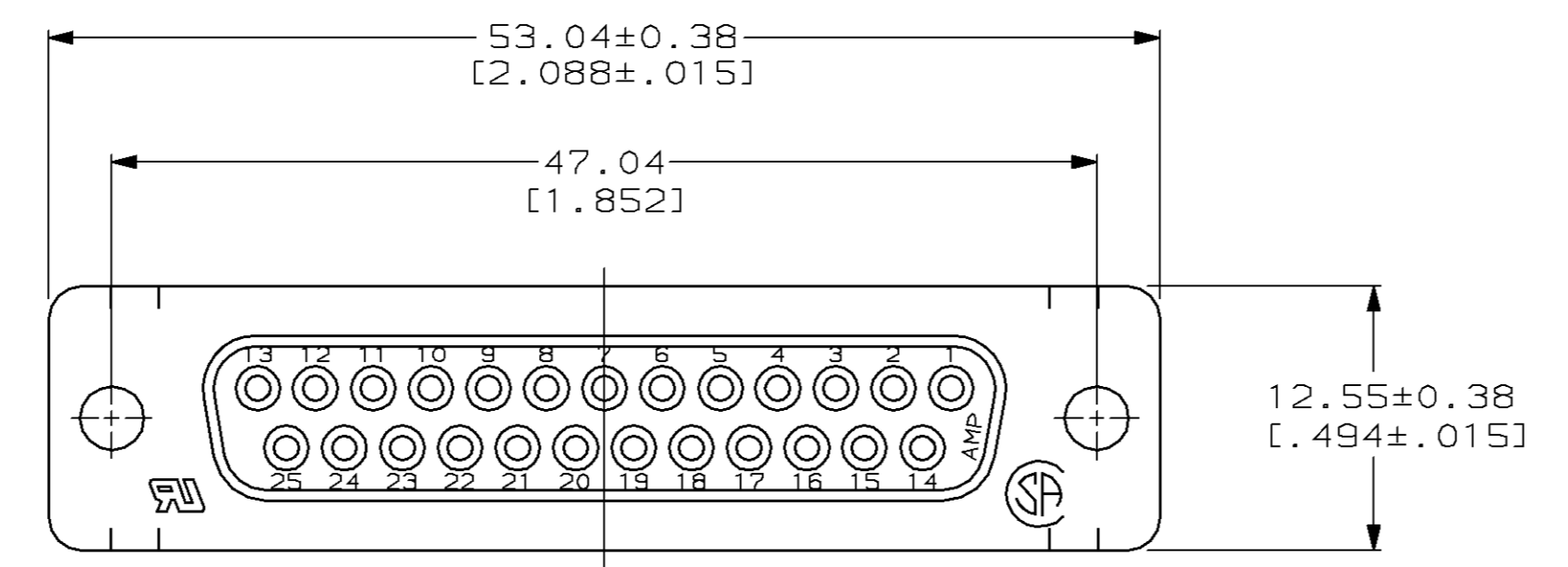
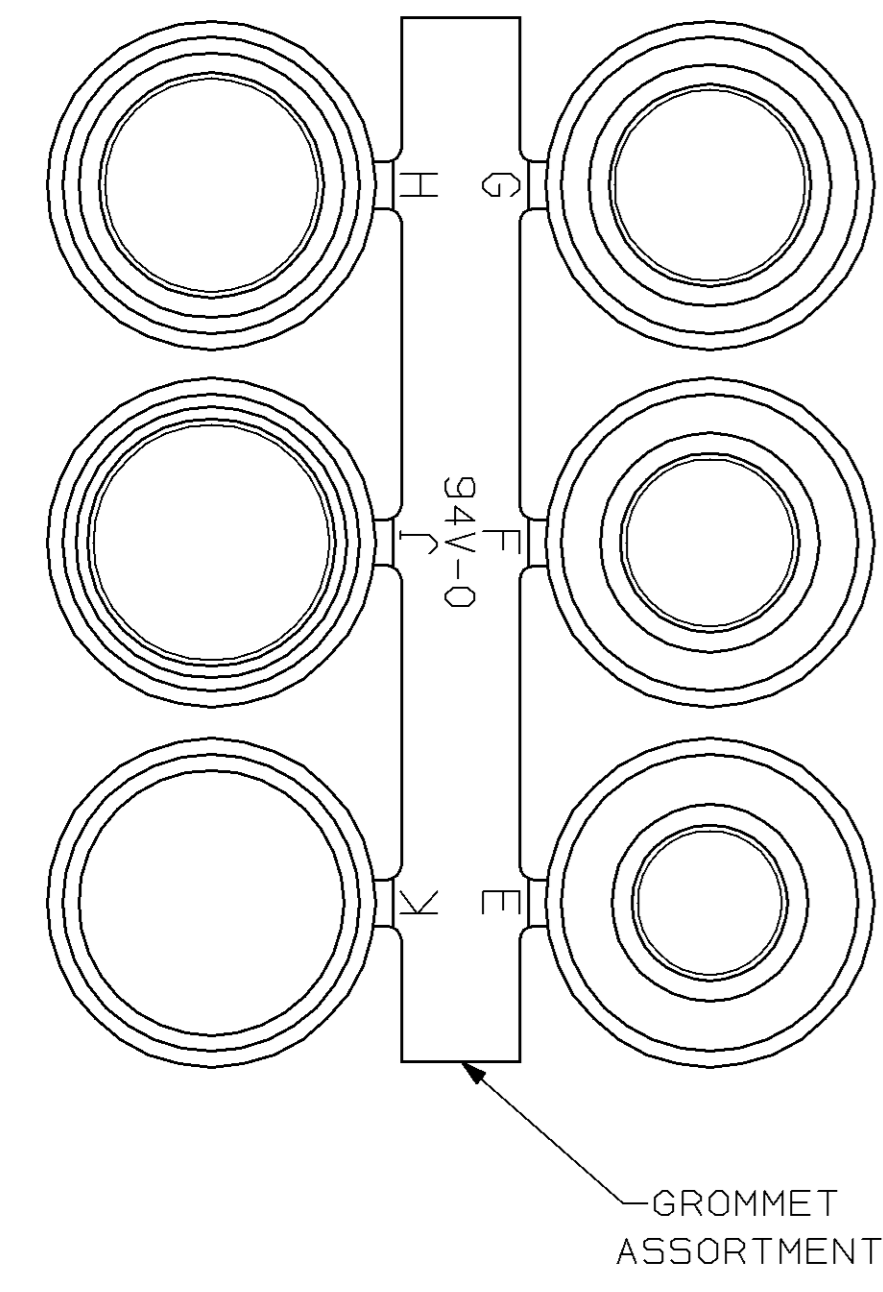

1. CONTACTS ACCEPT 22-26 AWG RANGE.
2. POLYESTER OR NYLON, GLASS FILLED, UL 94V-0 RATED, BLACK.
3. PVC, UL 94V-0 RATED, BLACK.
4. PHOSPHOR BRONZE PER ASTM B 103.
5. CARBON STEEL.
6. CABLE CLAMPS: ZINC; SCREWS & NUTS: CARBON STEEL.
7. GOLD PLATING PER MIL-G-45204; NICKEL PLATING PER QQ-N-290; TIN PLATING PER MIL-T-10727; COPPER PLATING PER MIL-C-14550; ZINC PLATING PER ASTM B633, TYPE III, CLASS SC1, CLEAR CHROMATE.
8. GOLD FLASH FOR A LENGTH OF 2.54 [0.100] MIN FROM MATING END, 2.54µm [0.000100] MIN TIN OR TIN-LEAD ON OPPOSITE END FOR A LENGTH OF 6.60 [0.260] MIN, BOTH OVER 0.76µm [0.000030] MIN NICKEL ON ENTIRE CONTACT.
9. 5.08µm [0.000200] MIN TIN OVER 1.27µm [0.000050] MIN COPPER.
10. MOUNTING SCREWS & NUTS: 3.81µm [0.000150] MIN ZINC; FILISTER HEAD SCREWS: ZINC.

DO NOT SCALE PRINT. UNLESS SPECIFIED DIMENSIONS IN mm [INCHES]		DR 1-22-90 W.G. LENKER	749814-3 PART NO	
TOLERANCES: ON ; 2 PLC DEC ± 0.13 [0.005] 3 PLC DEC ± - ANGLES ± -		CHK 6-4-90 R STONE	AMP INCORPORATED Harrisburg, Pa. 17105	
MATERIAL HOUSING: 2 GROMMETS: 3 CONTACTS: 4 SHELLS: 5 HARDWARE: 6		APPD 6-5-90 B TAYLOR	NAME RECEPTACLE KIT, UNASSEMBLED, SIZE 3, 25 POSITION, METAL SHELL, AMPLIMITE® HDE-20	
FINISH 7 CONTACTS: 8 SHELLS: 9 HARDWARE: 10		APPD 6-6-90 J ASSINI	PRODUCT SPEC 108-40011	
SCALE 3:1		APPLICATION SPEC 114-40003	SIZE D	CAGE CODE 00779
WEIGHT -		DRAWING NO 749814-3		SHEET 1 OF 1